

DN SERIES

Models: 235/240DN | 355/360DN

Detachable Neck, Ground Bearing



Choice DN Series trailers are well equipped as standard with many features you would expect to find on a higher-priced, more expensive brand. All-beam main frame construction, removable outriggers, radial tires, and LED lights are just a few of the standard features on a Choice Trailer. Quality materials and components, combined with advanced design and fabrication techniques, all at a price your budget can handle. With operating costs on the rise, choosing to invest your money wisely is a must... **Your Choice is Now Clear.**



16435 Katy Freeway
Houston, Texas 77094
1-281-646-8080
Fax: 281-646-8082
info@choicetrailers.com

DN SERIES

Models: 235/240DN | 355/360DN

Hydraulic Detachable Gooseneck - Ground Bearing

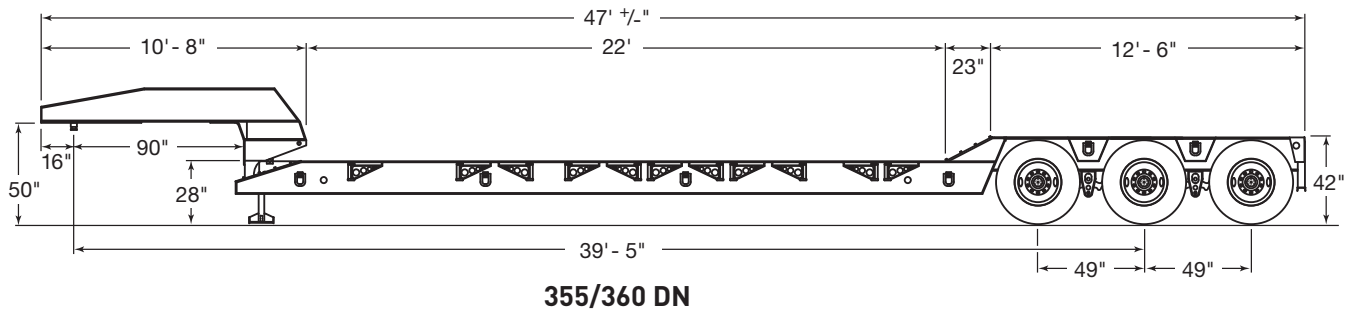
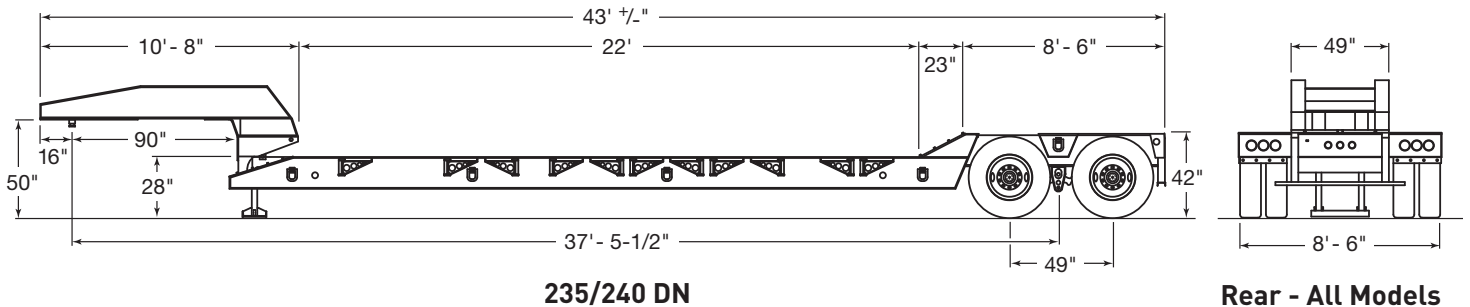

STANDARD DN SERIES SPECIFICATIONS

- Hydraulic detachable gooseneck, dual hydraulic cylinders
- Self-contained hydraulic system.
- All-beam main frame construction.
- 22' load bed.
- 12" swing-out removable outriggers; 12 per side, evenly spaced.
- 12 each D-rings; 6 per side, evenly spaced.
- Excavator boom cut-out over rear axles.
- Hutch H9700 series spring suspension or trailer air ride suspension.
- 25,000# capacity 5" round axles; 10-stud "unimount" hubs & drums, 16-1/2" x 7" brakes with automatic slack adjusters.
- 255/70 R 22.5 16-ply tubeless radial tires mounted on steel disc "unimount" wheels.
- U.S. D.O.T. approved electrical system with sealed wiring harness.
- LED lamps (lighting)



16435 Katy Freeway, Houston, TX 77094
Tel: 1-281-646-8080 Fax: 281-646-8082
www.choicetrailers.com
e-mail: info@choicetrailers.com

NOTE: specifications subject to change without notice.
Add 2" to overall length for air ride equipped trailers.